

Safety for Hydraulics

Proportional Valves, Sectional Design
Series SVC 25

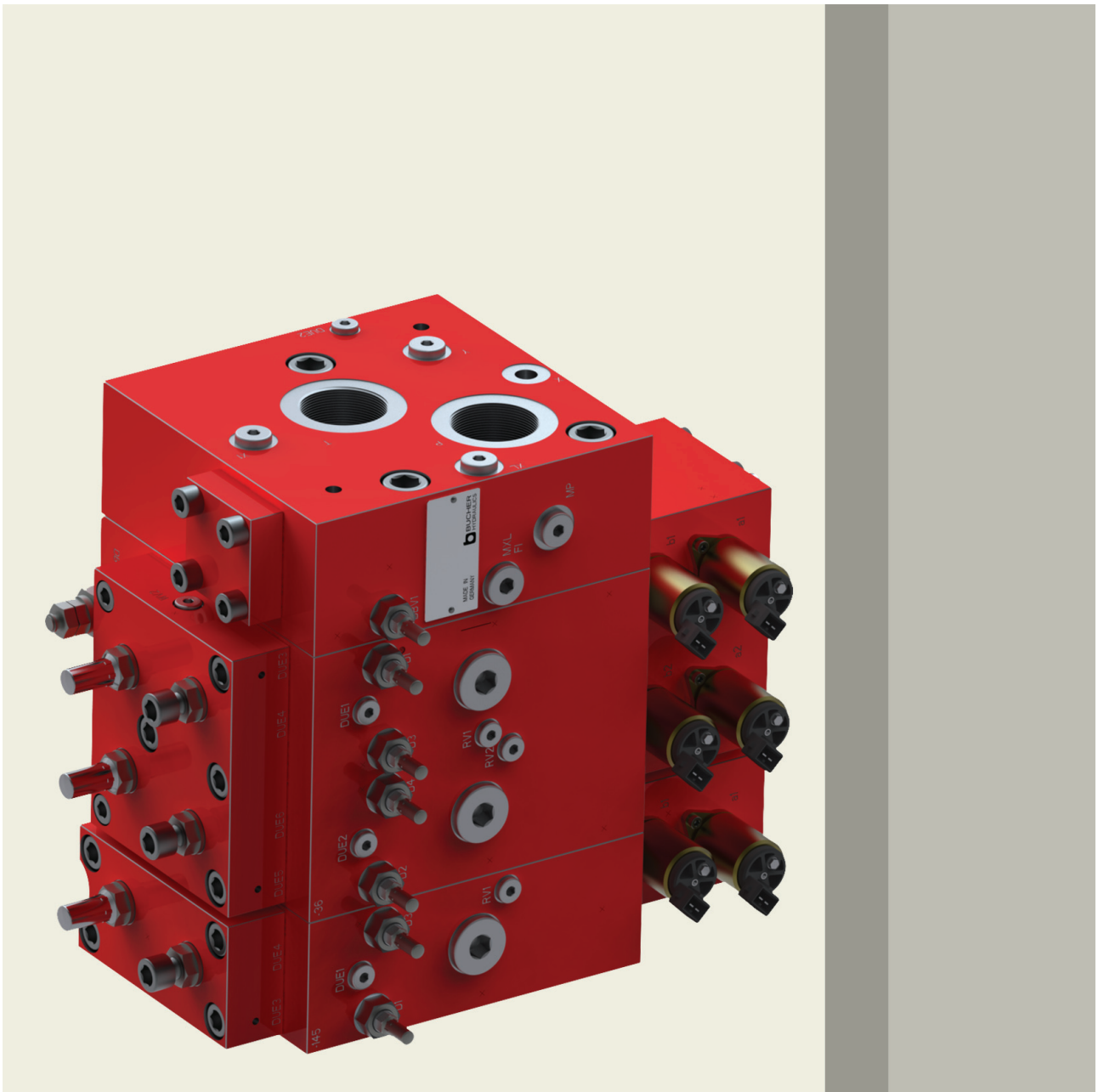

motion and progress

Contents

Page

1	Description	3
2	Technical data	3
3	Performance graphs	5
	3.1 Control characteristics, electro-hydraulic, proportional	5
	3.2 Flow-control characteristics	5
	3.3 Primary-pressure cut-off	6
	3.4 Pressure differential at directional valve spool – Return	6
	3.5 Secondary pressure relief (optional)	6
4	Circuit diagram	7
5	Dimensions	9
	5.1 Complete valve with threaded ports	9
	5.2 Complete valve with SAE flanged ports	11
	5.3 SAE flanged ports	13
6	Ordering code	13
	6.1 Inlet module	13
	6.2 End module	14
	6.3 Actuator module	15
7	Modules	16
	7.1 Inlet modules	16
	7.2 End modules: no actuator section	16
	7.3 Actuator modules	17
	7.4 Spool type / Symbol	18

1 Description

Our sectional proportional valves regulate the flow rate to the actuator by means of an internal closed-loop control system. Load-independent flow control is guaranteed by individual pressure compensators upstream of each proportional directional valve (load-sensing principle). The highly adaptable modular system consists of an inlet module, actuator modules (with up to eight sections), and an end module and is specially designed for use in mobile hydraulics. The user can be assured that the right system is always available for every application.

This is accomplished by:

- Various inlet modules
- Actuator modules with individual compensator and optional, individually adjustable, primary and secondary pressure-relief valves
- Various types of operators

Use Section 6, "Ordering code", to establish the complete valve code.

2 Technical data

General characteristics	Description, value, unit
Design	proportional valves, sectional design, spool type
Types of operators	<ul style="list-style-type: none"> • electro-hydraulic, proportional • hydraulic • manual • electro-hydraulic proportional - manual, combined • electro-hydraulic proportional - hydraulic, combined • for other types, please consult Bucher
Size	port sizes to DIN 3852, DIN ISO 6162
Mounting attitude	unrestricted, but ensure good air-bleeding
Ambient temperature range	-30 °C ... +60 °C

Hydraulic characteristics	Description, value, unit
Hydraulic fluid	HL and HLP mineral oil to DIN 51 524; for other fluids, please consult BUCHER
Hydraulic fluid temperature range	-20 °C ... +80 °C, recommended +20 °C ... +60 °C
Viscosity range	10...380 mm ² /s (cSt), recommended 15...100 mm ² /s (cSt)
Minimum fluid cleanliness Cleanliness class to ISO 4406 : 1999	class 20/18/15
Maximum pump flow rate	750 l/min
Maximum actuator flow rate	500 l/min (600 l/min – consult Bucher)
Maximum pump pressure	370 bar
Maximum load pressure	420 bar
Maximum tank pressure	50 bar
Maximum tank pressure with elec. pilot stage	5 bar

Hydraulic operation	Description, value, unit
Pilot-pressure range	6 ... 20 bar
Pressure rating of pilot circuit	max. 50 bar

Size	Description, value, unit	Port types	
		Model with threaded ports	Model with SAE flanged ports
Actuator	A / B	G 1½"	SAE 1¼" 6000 PSI
Pump	P	G 1½"	SAE 1¼" 6000 PSI
Tank	T	G 1½"	SAE 1½" 3000 PSI
Load sensing	XL	G ¼"	G ¼"
Pump for pilot stage	X	G ¼"	G ¼"
Tank for pilot stage	Y	G ¼"	G ¼"
Test point for pump pressure	MP	G ¼"	G ¼"
Test point for tank pressure	MT	G ¾"	G ¾"

Electrical characteristics	Description, value, unit	
Control current at opening point	24 V 12 V	350 mA 700 mA
Control current at max. stroke	24 V 12 V	675 mA 1350 mA
Hysteresis with 100 Hz PWM signal (from control current at max. stroke)		± 3 %
Protection class to EN 60 529		IP 65
Insulation class to VDE 0580		H
Supply voltage		24 V / 12 V
Coil resistance at 20 °C	24 V 12 V	21.2 Ω ± 5 % 5.3 Ω ± 5 %
Coil resistance at 60 °C	24 V 12 V	24.5 Ω ± 5 % 6.1 Ω ± 5 %
Power consumption at max. spool stroke (coil resistance at 60 °C)		10.4 VA
Maximum current for 100 % relative duty cycle with:	24 V 12 V	750 mA 1500 mA

3 Performance graphs

3.1 Control characteristics, electro-hydraulic, proportional

$Q = f(\Delta p_{st})$ Flow rate - Energising signal characteristic

Q [%]

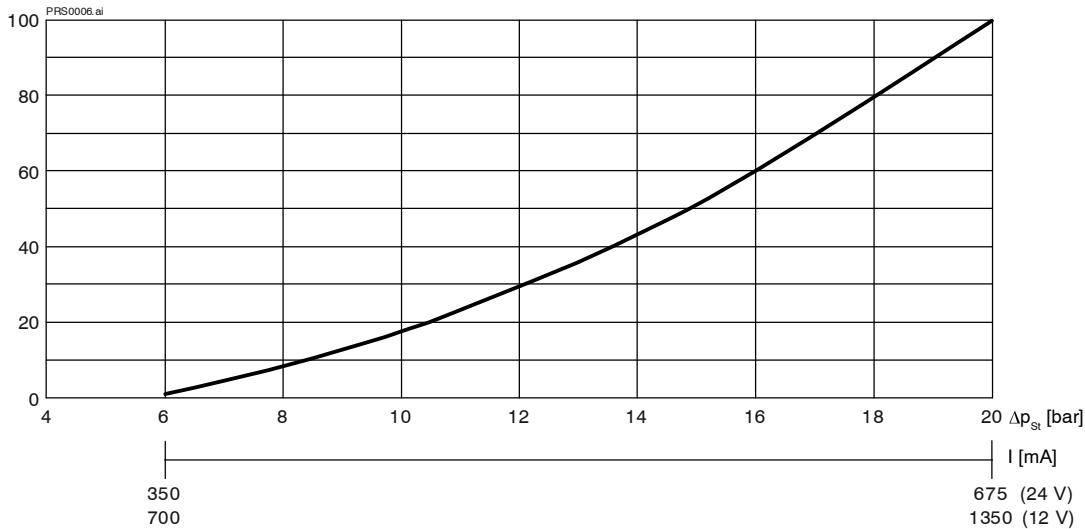

IMPORTANT!

The cross-sectional geometry of the spool and the pressure-differential setting are factory-set so that the valve's working range lies within the characteristic diagram.

3.2 Flow-control characteristics

$Q = f(\Delta p = p_{Pumpe} - p_{Last})$ Flow rate - Pressure differential characteristic

Q [l/min]

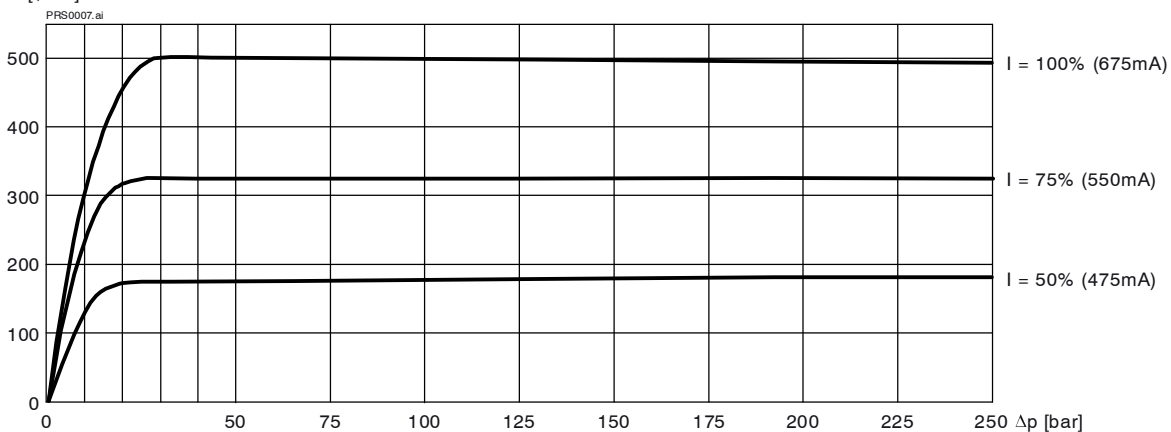

3.3 Primary-pressure cut-off

$Q_{A/B} = f(p_{XL})$ Actuator flow rate - Load pressure characteristic

Q [l/min]

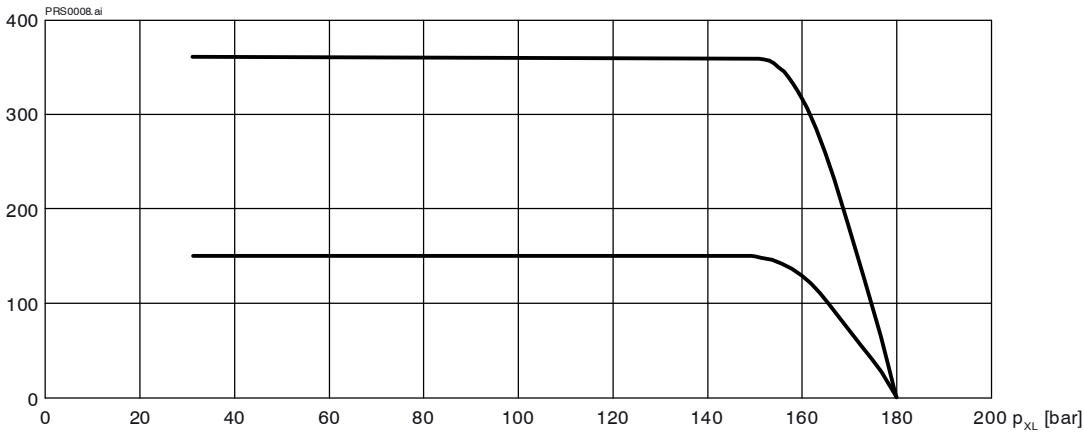

3.4 Pressure differential at directional valve spool – Return

$\Delta p_{A/B \rightarrow T} = f(Q_{A/B})$ Pressure differential - Flow rate characteristic

Δp [bar]

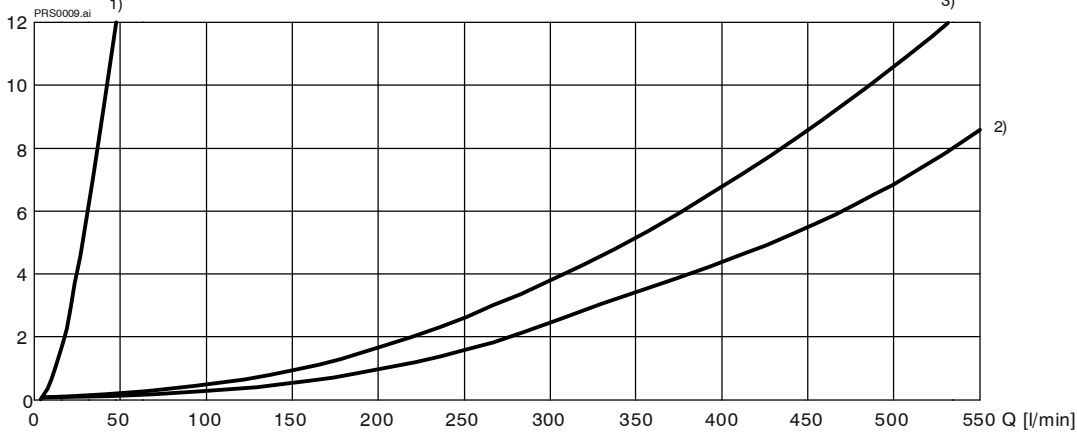

- 1) Spool type C in neutral position
- 2) Spool type C at 100% energisation
- 3) Spool type A at 100% energisation

3.5 Secondary pressure relief (optional)

$p_{A/B} - p_T = f(Q_{A/B \rightarrow T})$ Secondary pressure - flow rate characteristic

p [bar]

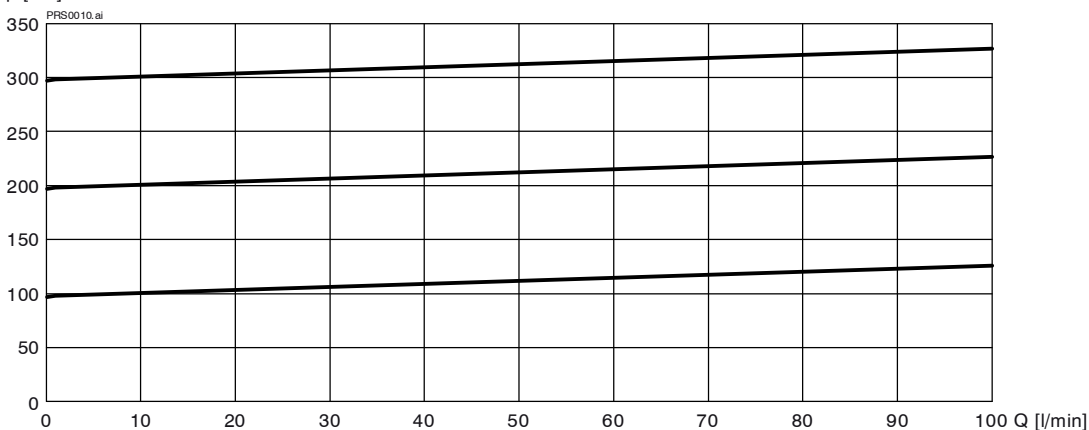

4 Circuit diagram

Example: Proportional valve with an inlet module, one dual actuator module, and an end module.

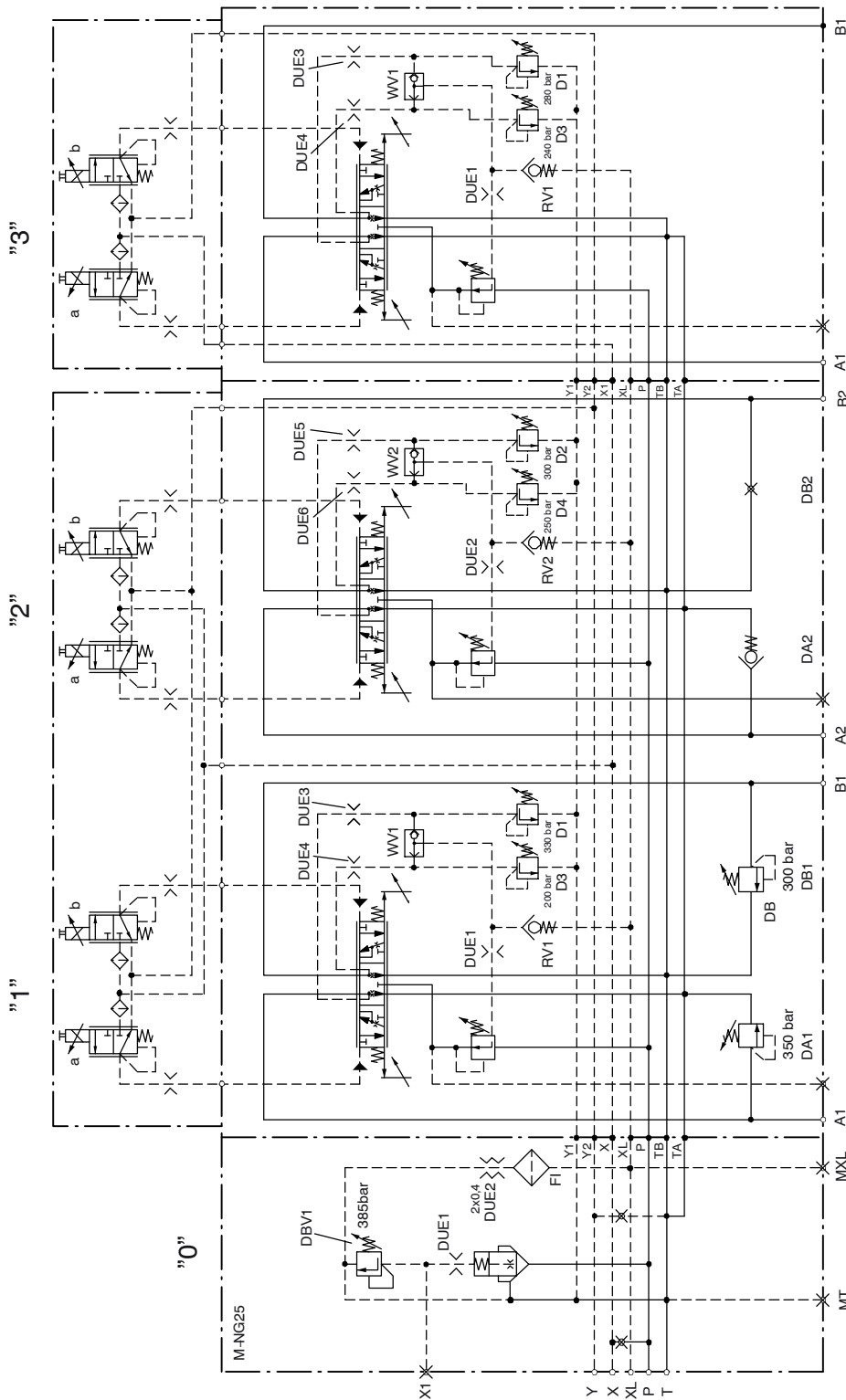

Bestellbeispiel / Ordering Example

"0" = SVC25 - M01 - G04 - 385 - 00 - 00 - 0 - B

"1" = SVC25 - 1 - 1Y1X - 330/200 - C500/500 - E20 - GX0 - D350/D300 - B

"2" = SVC25 - 2 - 2Y1X - 300/250 - C420/200 - E20 - GX0 - N000/S000 - B

"3" = SVC25 - 3 - 0D00 - 100/250 - C290/290 - E20 - X11 - S000/S000 - A SVC25 - 3 - 0D0X - 280/240 - C420/250 - E20 - GX0 - S000/S000 - B

Hinweis: Wenn Magnet "a" angesteuert wird, öffnet das Ventil von "P" nach "B". / Note: when solenoid "A" is energised, the valve opens from "P" to "B".

Example: Proportional valve with an inlet module, three single actuator modules, and an end module.

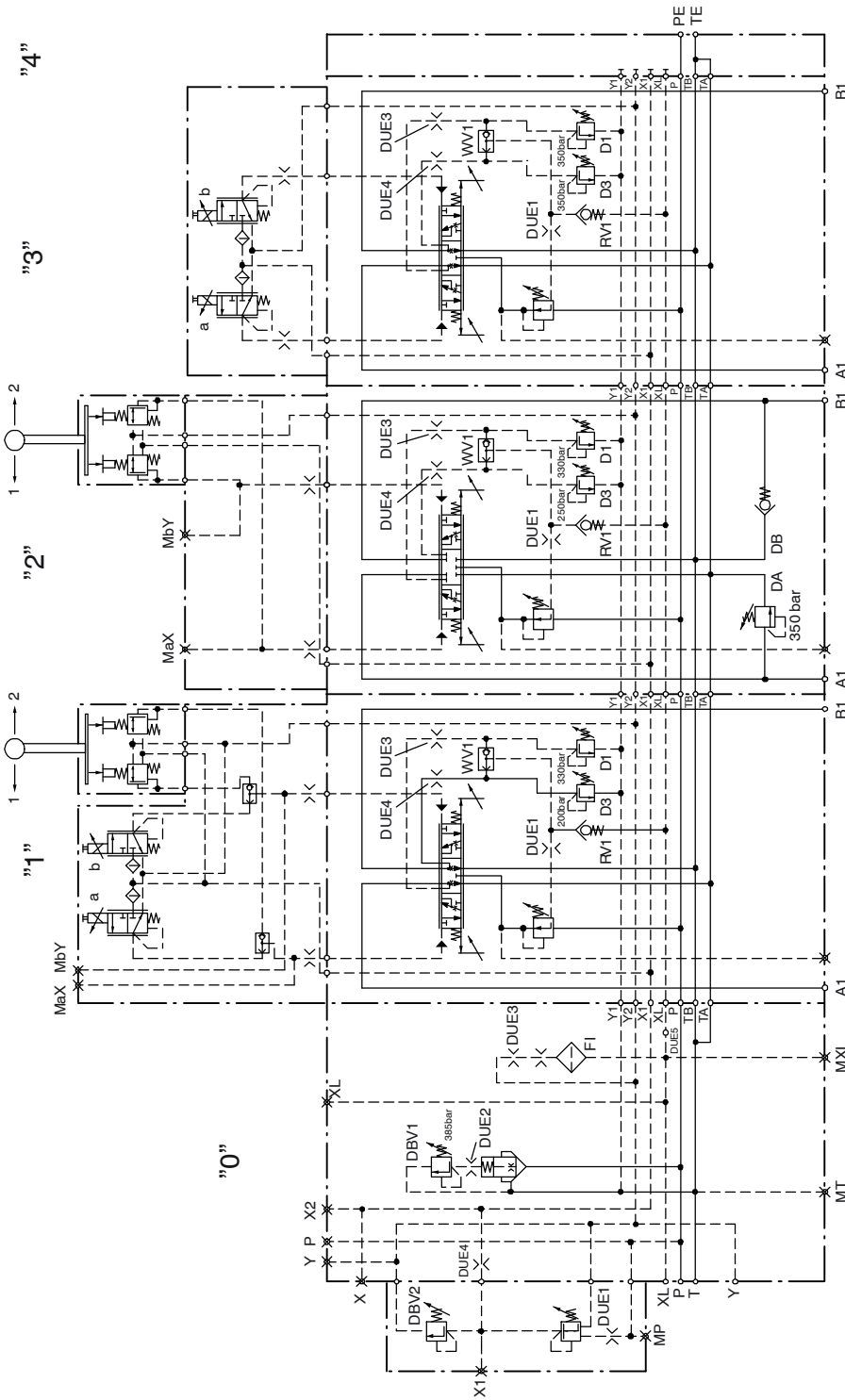

Bestellbeispiel / Ordering Example

"0" = SVC25 - M01 - G04 - 385 - 00 - 00 - 0 - B SVC25 - L01 - F02 - 385 - 00 - 00 - 0 - B

"1" = SVC25 - 1 - 0Y0X - 330/200 - C500/500 - K2F - FX0 - S000/S000 - B

"2" = SVC25 - 2 - 0Y1X - 330/250 - A420/200 - H9F - FX0 - D350/N000 - B

"3" = SVC25 - 3 - 0Y0X - 350/350 - C400/400 - E20 - FX0 - S000/S000 - B

"4" = SVC25 - E22 - 000 - B

Hinweis: Wenn Magnet "a" angesteuert wird, öffnet das Ventil von "P" nach "B" / Note: when solenoid "A" is energised, the valve opens from "P" to "B".

5.2 Complete valve with SAE flanged ports

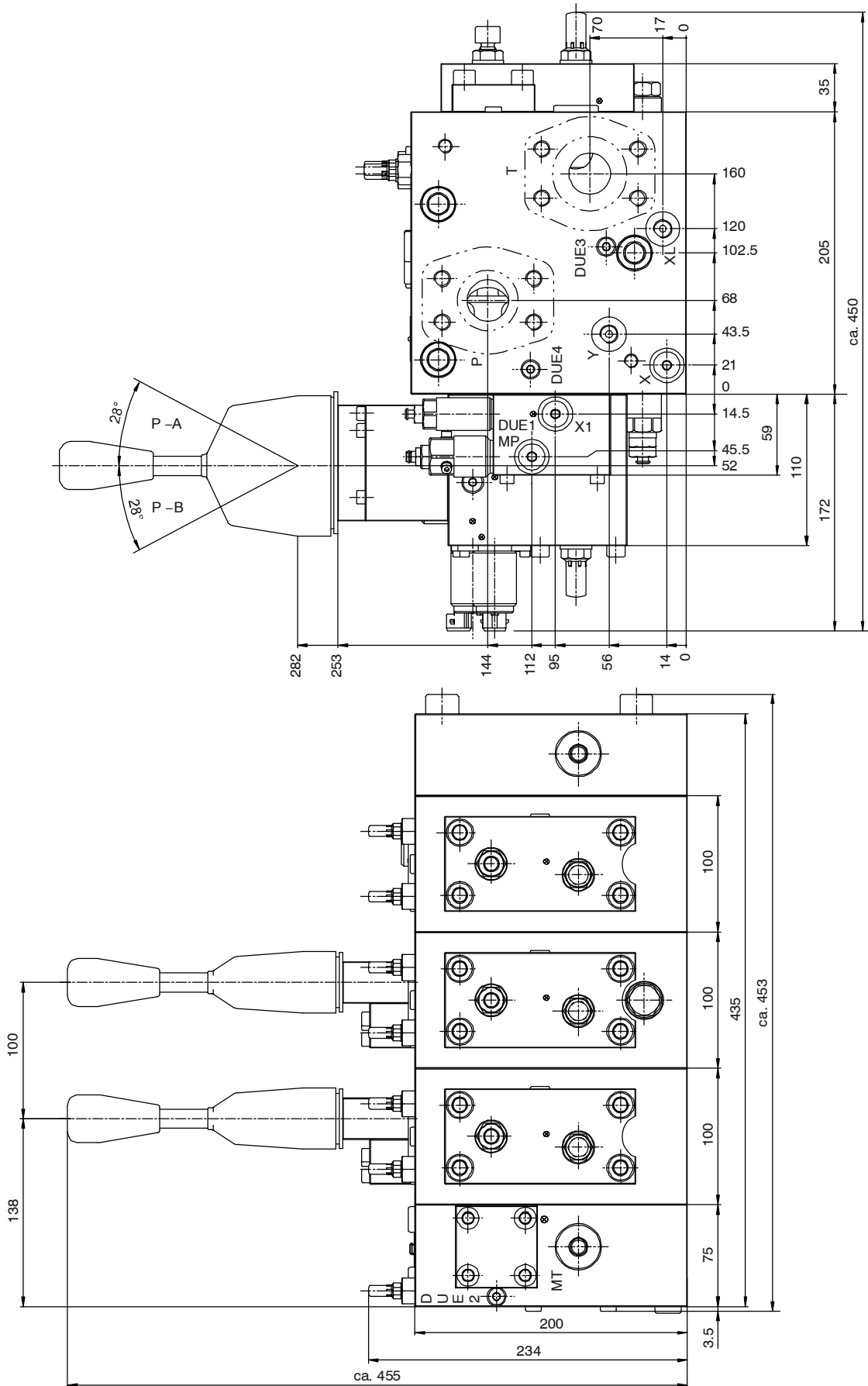

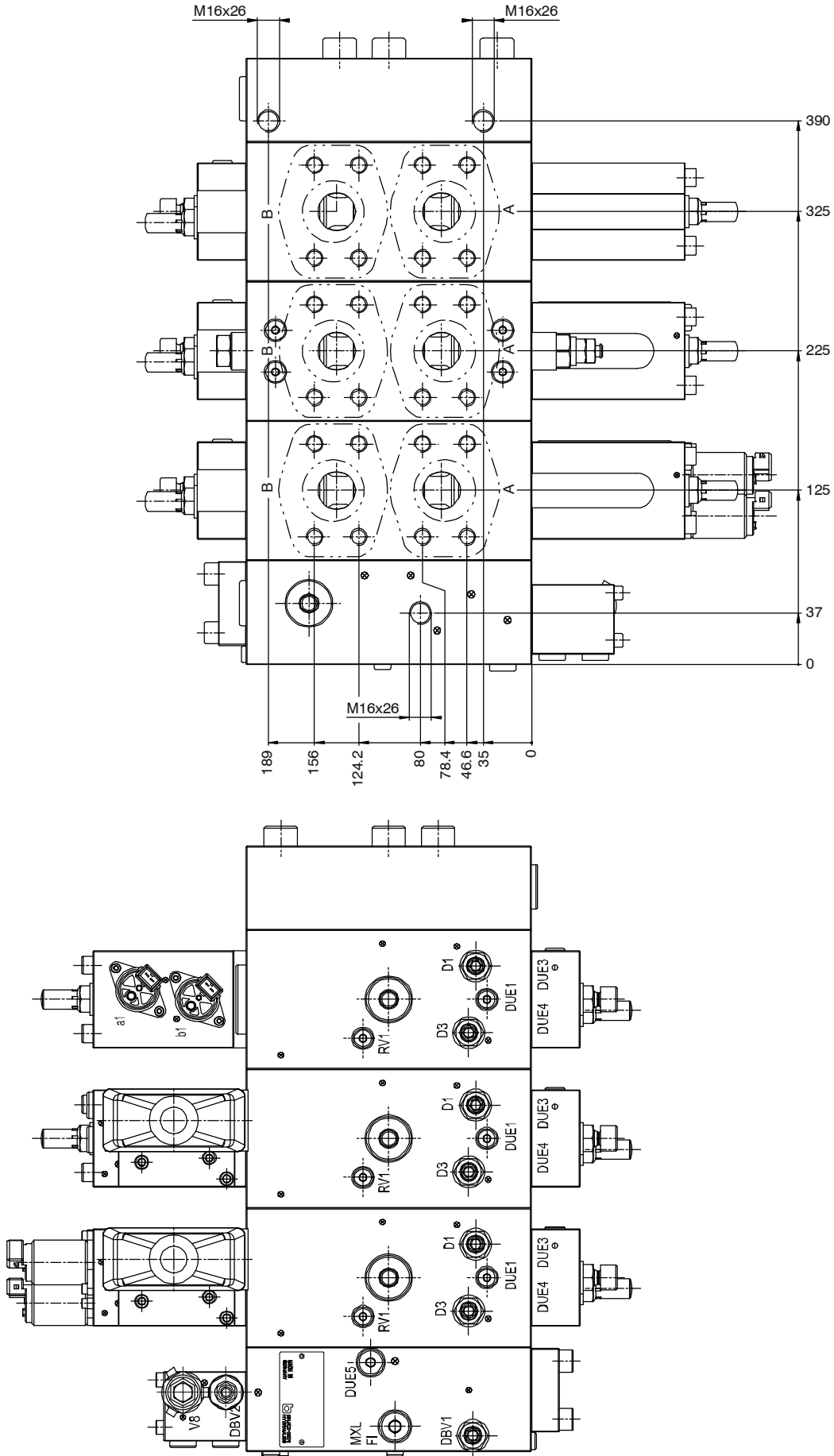

5.3 SAE flanged ports

Ports A, B, P, PE

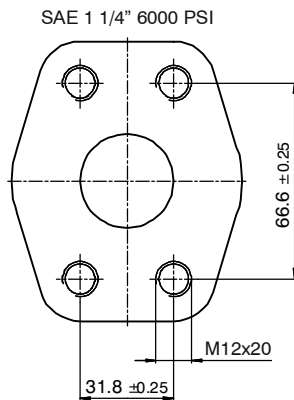

Ports T, TE

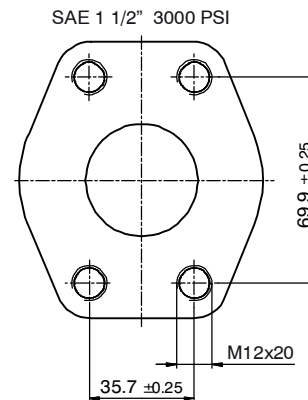

6 Ordering code

6.1 Inlet module

SVC 25 - M 0 1 - G 0 4 - 385 - 00 - 00 - 0 - B - Z

SVC = proportional valve in sectional design

25 = nominal size

Circuit options: see Section 7.1

G = without aux. valve

M = with system pressure relief

L = with system pressure relief, pilot-pressure conditioning (pressure reducing and pressure relief)

V = 3-way pressure compensator

0 = without ports for external pilot-oil filtration (**standard**)

1 = with ports for external pilot-oil filtration

1 = with LS unloading (**standard**)

0 = without LS unloading

Connection method:

G = pipe threads

F = SAE flanges

0 = without pressure-peak reducing valve 50 bar

1 = with pressure-peak reducing valve 50 bar

1 = pilot-pressure supply "X" internal / pilot-pressure drain "y" internal

2 = pilot-pressure supply "X" internal / pilot-pressure drain "y" external

3 = pilot-pressure supply "X" external / pilot-pressure drain "y" internal

4 = pilot-pressure supply "X" external / pilot-pressure drain "y" external

... = system pressure relief in bar

000 = with circuit option G

... = pilot-pressure reducing in bar

00 = with circuit options G, M and V

... = pilot-pressure relief in bar

00 = with circuit options G, M and V

0 = without AVR (**standard**)

1 = with AVR (automatic flow reduction)*

... = series identifier (e.g. B)

... = special feature as per description (e.g. Z)

* Consult Bucher / configuration by Technical Sales

6.2 End module

SVC 25 - E 1 1 - 1 0 0 - B - Z

SVC = proportional valve in sectional design

25 = nominal size

E = end plate

P-port

1 = with P-port (**standard**)

2 = SAE flanges

0 = without

T-port

1 = with T-port (**standard**)

2 = SAE flanges

0 = without

0 = without XL-port (**standard**)

1 = with XL-port

0 = without pilot-oil supply

0 = without pilot-oil drain

... = series identifier (e.g. B)

... = special feature as per description (e.g. Z)

6.3 Actuator module

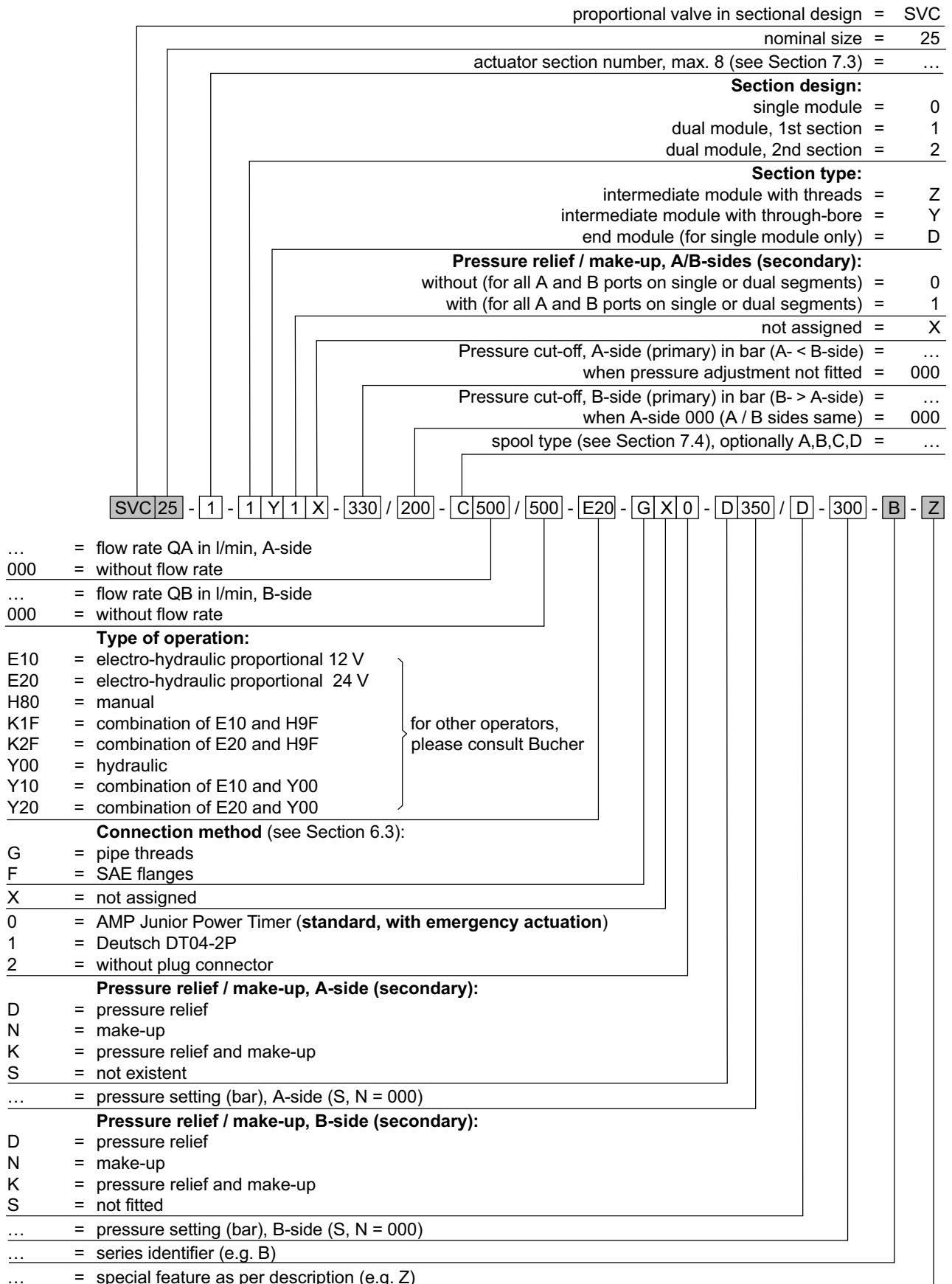

7 Modules

7.1 Inlet modules

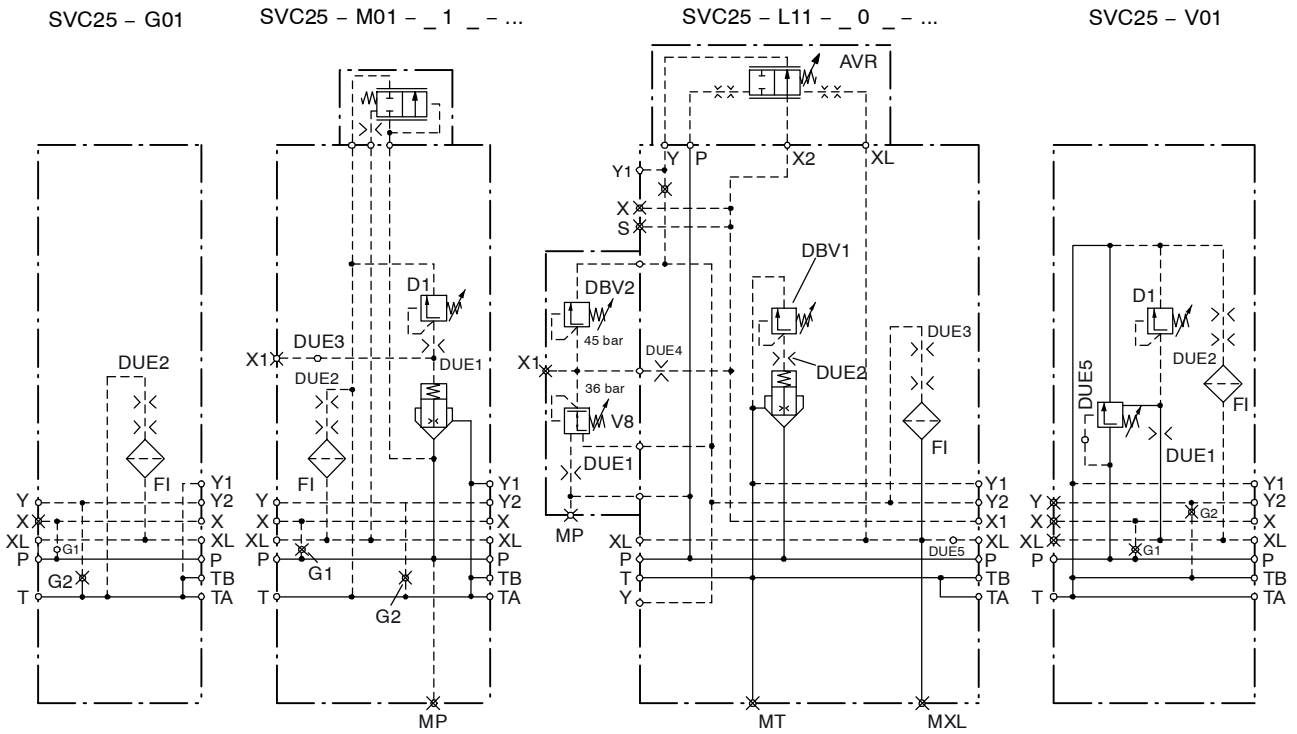

7.2 End modules: no actuator section

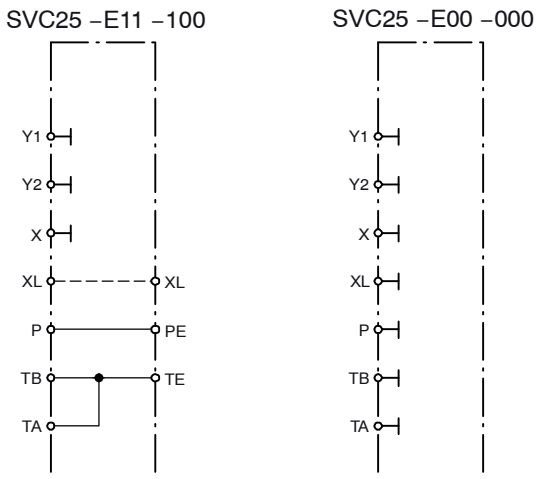

7.3 Actuator modules

Two actuator sections in one intermediate module

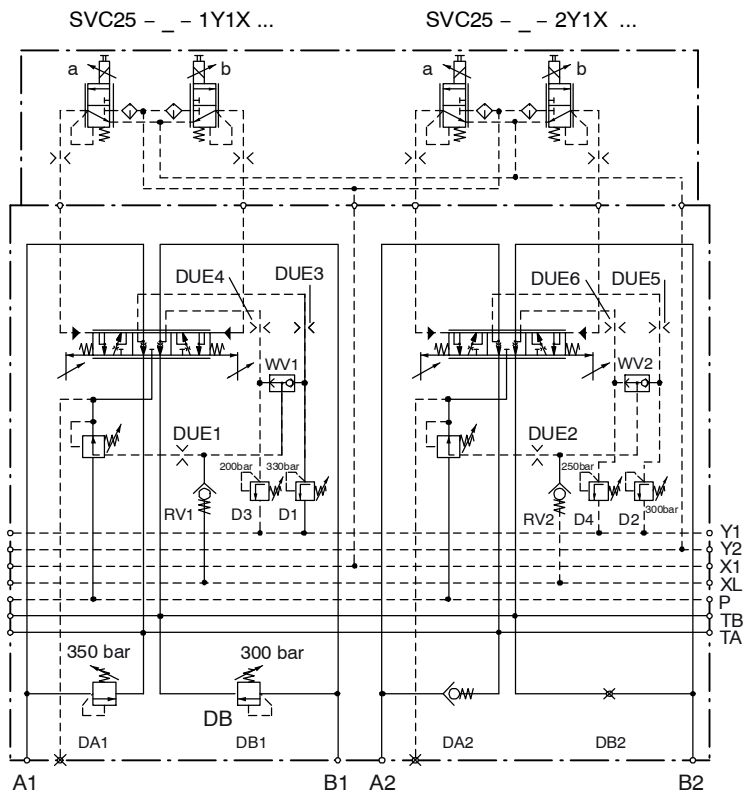

One actuator section as intermediate module or end module

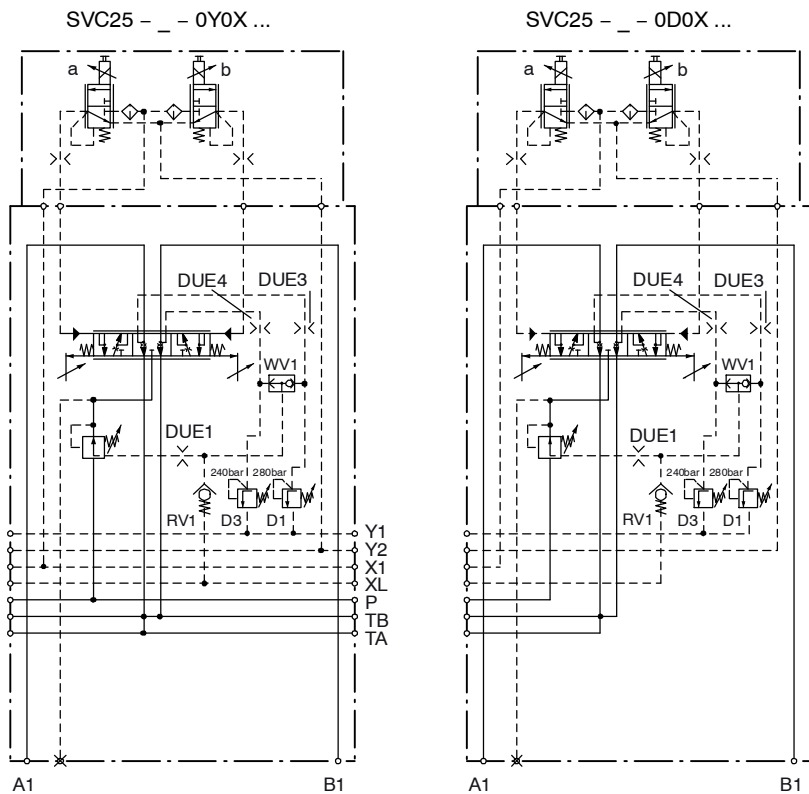

7.4 Spool type / Symbol

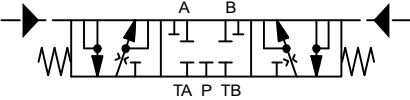
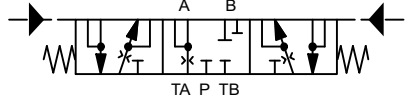
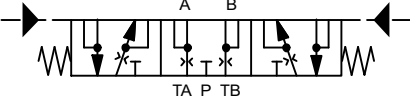
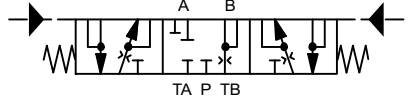
5/3 way functions	Description for ordering code
	A
	B
	C
	D

info.rs@bucherhydraulics.com

www.bucherhydraulics.com

© 2010 by Bucher Hydraulics Remscheid GmbH, D-42861 Remscheid

All rights reserved.

Data is provided for the purpose of product description only, and must not be construed as warranted characteristics in the legal sense. The information does not relieve users from the duty of conducting their own evaluations and tests. Because the products are subject to continual improvement, we reserve the right to amend the product specifications contained in this catalogue.

Classification: 430.300.